



# **SAFER2028**

**National Nuclear Safety and Waste  
Management Research Programme 2023-  
2028 – updated for 2024**

**Suvi Karvonen**

---

# Contents

- Introduction to SAFER2028
- Doctoral Education Network - DENSE
- SAFER2028 Project portfolio
- SAFER2028 Project abstracts

# Introduction to SAFER2028

Public research programmes in Finland from 1990's

Research topics

Organisation

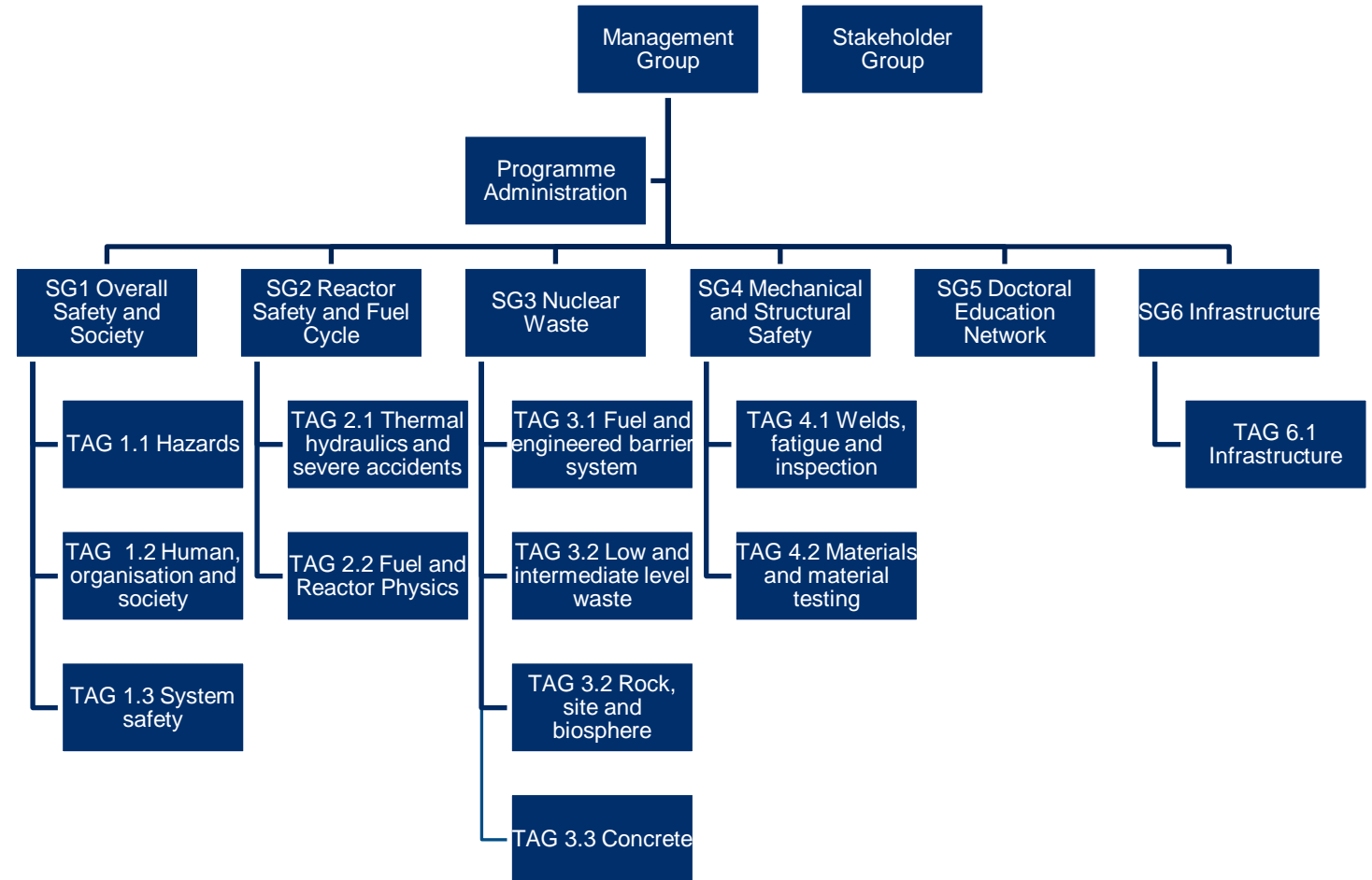

# SAFER2028 - National Nuclear Safety and Waste Management Research Programme 2023-2028

## Nuclear Waste Management Programmes

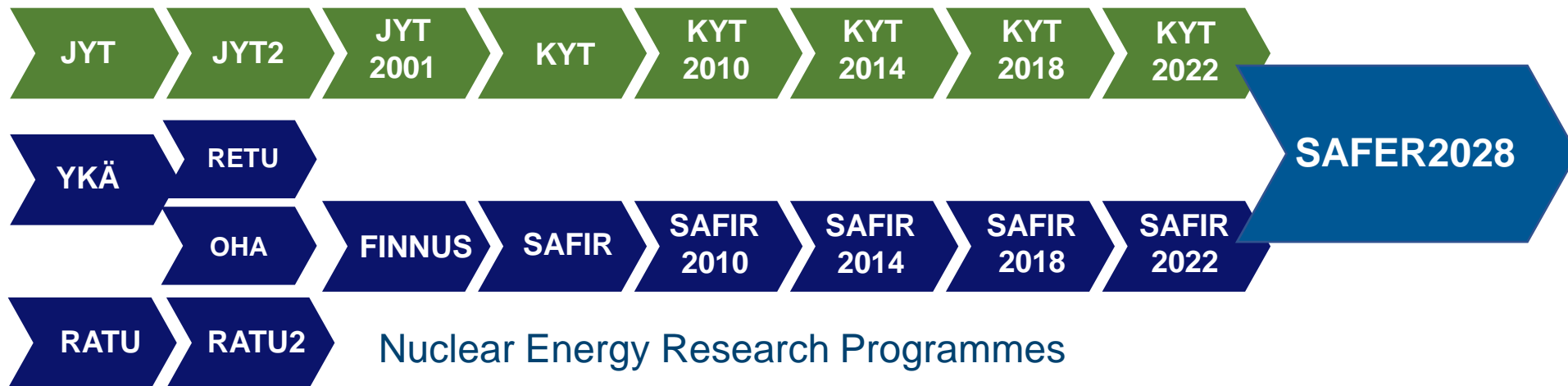

1990

2000

2010

2020

2030

## SAFER2028 – Research topics

- Framework Plan with four main research areas
  - Overall Safety and Society
  - Reactor Safety and Fuel
  - Decommissioning, Treatment and Long-term Safety of Nuclear Waste
  - Mechanical and Structural Safety of Nuclear Power Plants
- Cross-cutting topics: SMR's, International Collaboration, Infrastructure
- ~10 M€ funding per year, distributed through annual calls
- <https://safer2028.fi/framework-plan/>

# Programme organisation

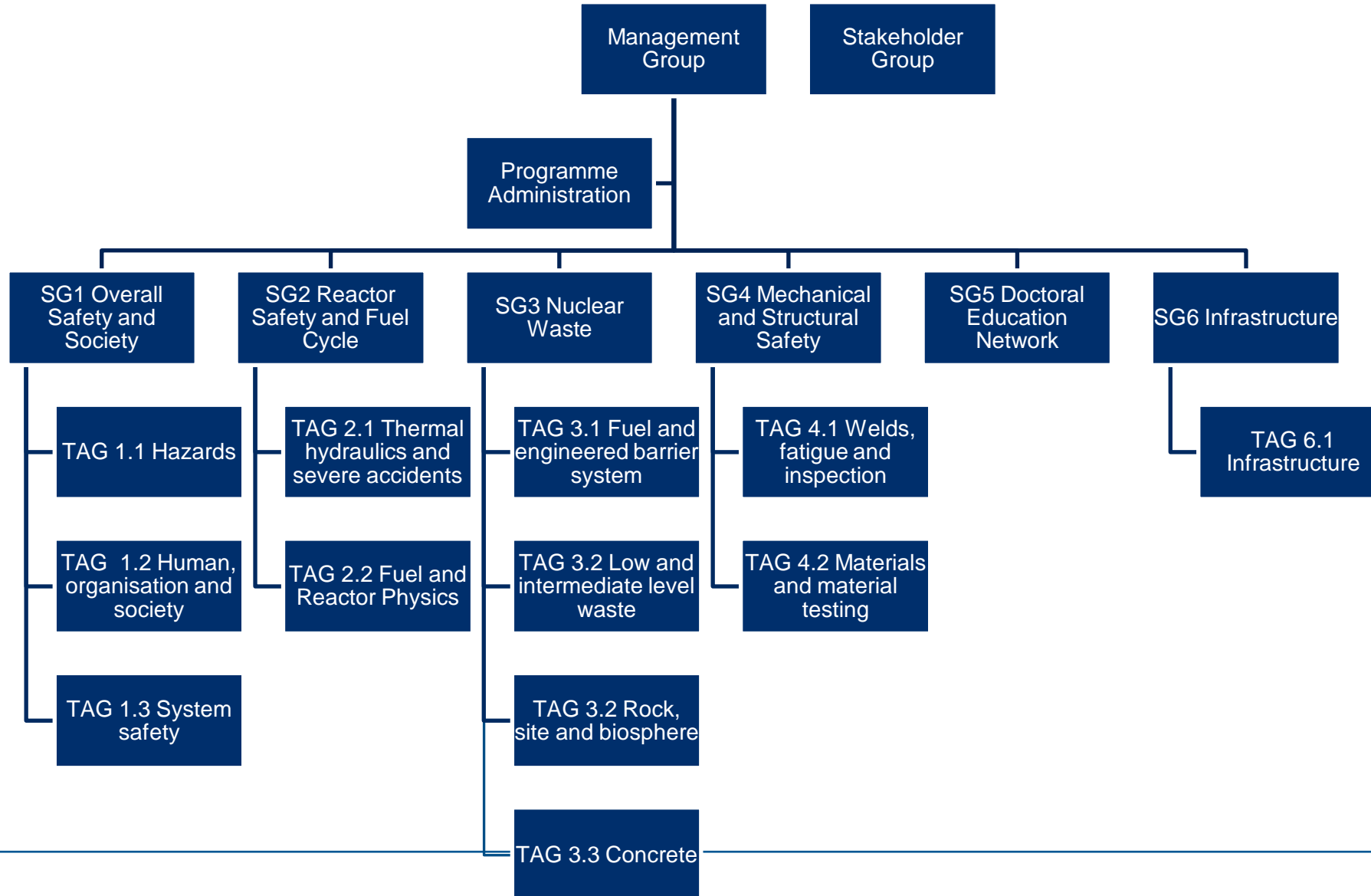

## Project types

- Project types
  - Research projects ("standard project") – 1-3 years
  - Excellence projects – 2-3 years
  - Doctoral Education Network (DENSE) projects (new) – 1-4 years
  - Infrastructure projects – 1-3 years
- Maximum 70 % funding from VYR
  - Certain exceptions apply for e.g. international membership fees
- International participants are welcome (with own funding)

## Evaluation Criteria for Research and Excellence Projects

- Projects's ability to develop expertise
- Significance to nuclear safety
- Usability for end users
- Scientific level of the proposal
- Novelty of the methods and new approaches
- Use of experimental facilities
- National and international collaboration and networking



# Participating organizations

- VTT Technical Research Centre of Finland (VTT)
- Lappeenranta-Lahti University of Technology (LUT)
- Aalto University (Aalto)
- University of Helsinki (HU)
- University of Turku (UTU)
- University of Jyväskylä (JyU)
- Geological Survey of Finland (GTK)
- University of Eastern Finland (UEF)
- Rock Mechanics Consulting Finland Oy (RMCF)
- AFRY Ab (AFRY)
- Finnish Meteorological Institute (FMI)
- Safram Oy (Safram)
- Åbo Akademi (Åbo A)
- Finnish Institute of Occupational Health (FIOH)
- Lilikoi Consulting (trade name Teemu Reiman) (Lilikoi)

# Doctoral Education Network - DENSE

### What is DENSE?

1. New doctoral student salary funding instrument in SAFER2028
2. Operational funding for scientific activities and mobility

**Purpose: networking of doctoral students – among themselves, between universities and with industry**

### DENSE Salary Funding

DENSE salary funding for doctoral students:

- Full-time doctoral students at universities (4 years)
- Thesis finalization (4–6 months) of part-time doctoral students
- Model: excellence projects with multiyear funding
- Full cost model, typical funding level 70%
- Evaluation by SG-DENSE (SGS)
- Funding decisions by SAFER MG

*Footnote:*

- General project funding like in KYT and SAFIR still available:
- Mainly applicable for part-time doctoral students

### Selection Process for Salary Funding

- Stronger weight on scientific level as a quality criterion
  - The mindset of the SAFIR/KYT programmes has been a challenge for universities: emphasis on practical applicability, not fundamental research
- Relevance for SAFER programme also requested
- Diversity of topics and disciplines within DENSE is an evaluation criterion
- SG-DENSE has members from universities and research organizations in addition to stakeholders
  - Outside experts may be consulted
  - Multidisciplinary SG supports multidisciplinary projects (if proposed)

### DENSE Operations and Networking

Activities of **all DENSE network members** to be funded through coordination project:

1. Networking events, such as **annual seminars** where students and members of the professional community meet and present
2. Research exchanges and visits (mobility) of both short (1–2 weeks) and long duration (up to 6 months), including infrastructure use-related costs
3. Participation in conferences, workshops and summer schools
4. Research publication-related costs

**Application procedures and selection criteria to be defined by DENSE Steering Group in early 2023**

- Probably 2-4 calls per year
- Announced to **DENSE mailing list** (to sign up, contact [jarmo.ala-heikkila@aalto.fi](mailto:jarmo.ala-heikkila@aalto.fi))

### DENSE Steering Group 2023

|        |                            |
|--------|----------------------------|
| STUK   | Jarkko Kyllönen            |
| Posiva | Antti Poteri               |
| TVO    | Nina Paaso                 |
| Fortum | Jyrki Kohopää (vice chair) |
| UEF    | Jarkko Akkanen             |
| HU     | Gareth Law (chair)         |
| LUT    | Juhani Hyvärinen           |
| VTT    | Jaakko Leppänen            |
| VTT    | Elina Huttunen-Saarivirta  |
| Aalto  | Andrea Sand                |
| UTU    | Pietari Skyttä             |

Interested? Contact [jarmo.ala-heikkila@aalto.fi](mailto:jarmo.ala-heikkila@aalto.fi)  
and sign up to DENSE mailing list!

<https://safer2028.fi/dense/>

To be announced:  
DENSE Annual Seminar!

## Doctoral Education Network - DENSE

- Bringing together all PhD students in Finland working on nuclear energy and waste management related topics
- Funding for PhD research
- Two annual calls for mobility and other funding to support the students
- Annual seminar
- <https://safer2028.fi/dense/>

# SAFER2028 Project portfolio

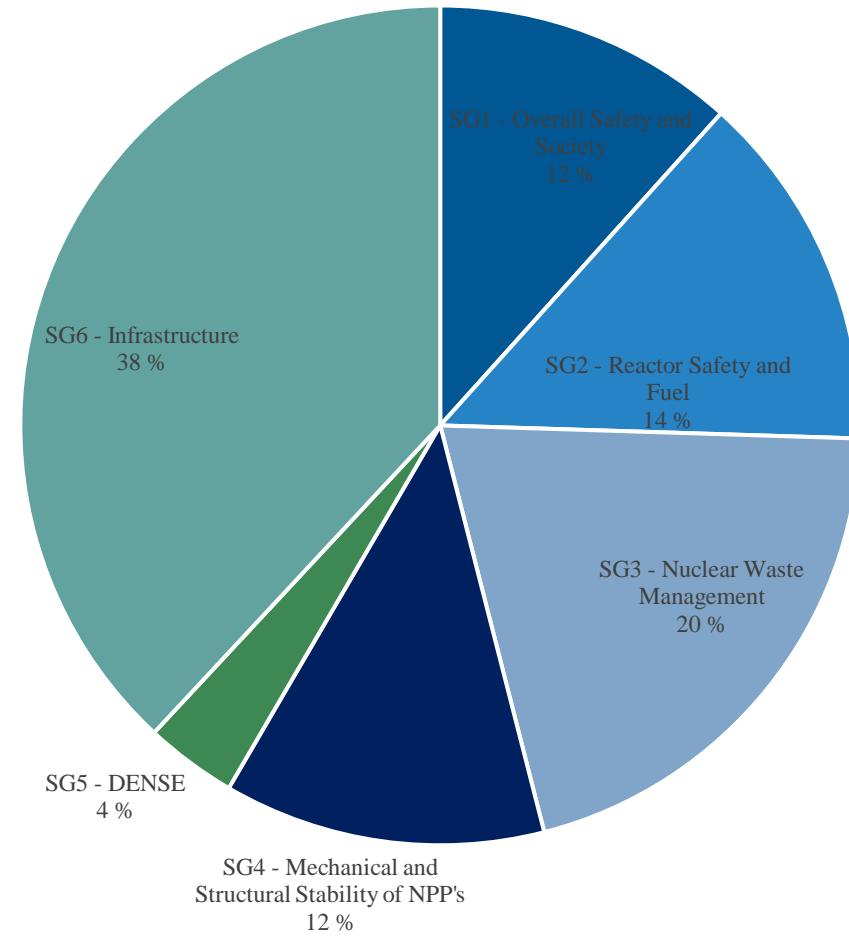

## Project portfolio in 2023

- 48 projects
- 5,0 M€ of VYR funding for research projects & 2,7 M€ for rental support of CNS
- 59 k€ for MG Small Projects

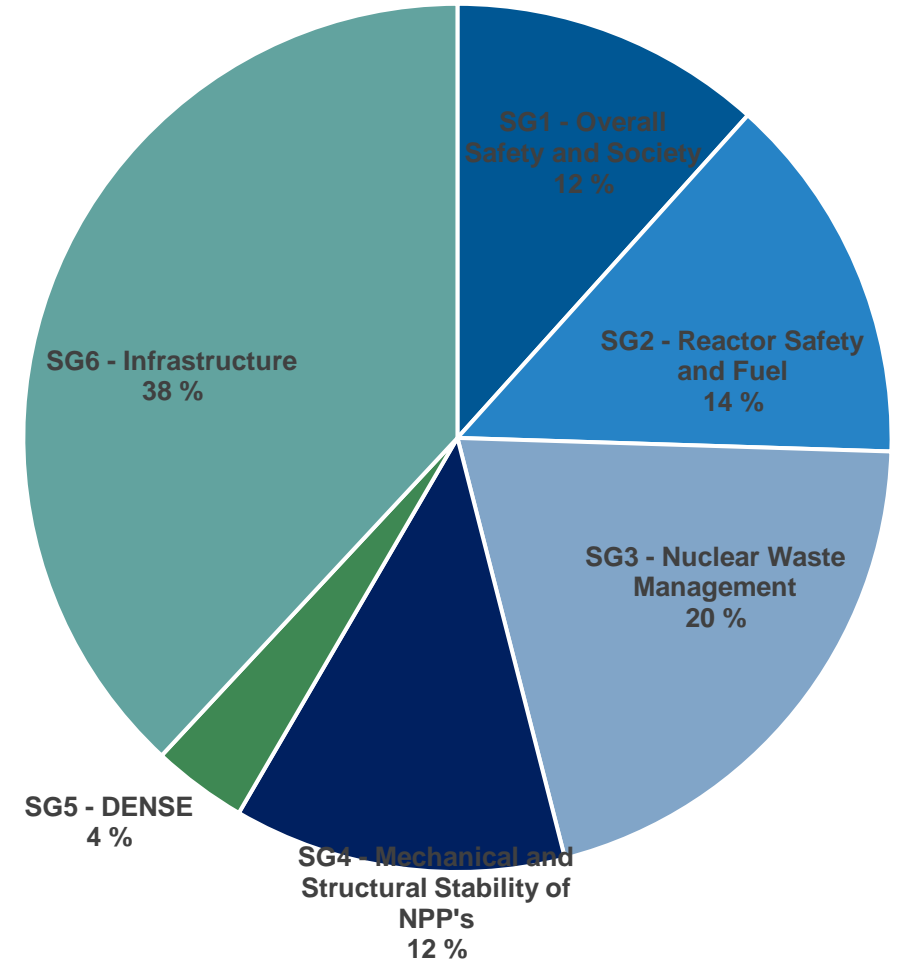

# SG1 – Overall Safety and Society

|                                            |                                                                                                                         |
|--------------------------------------------|-------------------------------------------------------------------------------------------------------------------------|
| <b>SG1</b>                                 |                                                                                                                         |
| <b>1.1 Hazards</b>                         |                                                                                                                         |
|                                            | <i>FASAANI - Fire behaviour and safety of nuclear infrastructure, VTT, Aalto</i>                                        |
|                                            | <i>MAWECLI - Marine and Weather Events in the Changing Climate as Potential External Hazards to Nuclear Safety, FMI</i> |
|                                            | <i>PRALINE - Probabilistic Risk Assessment Labour, Improvements aNd Extensions, VTT</i>                                 |
|                                            | <i>SERIOUS - Sensitivity and risk informed seismic hazard updates, VTT, RMCF, AFRY, HU</i>                              |
| <b>1.2 Human, organisation and society</b> |                                                                                                                         |
|                                            | <i>SCALA - Safety Culture and Leadership in Sociotechnical Changes and Transitions, VTT, Lilikoi</i>                    |
|                                            | <i>TONUS - Towards Nuclear Human Systems Integration, VTT, FIOH</i>                                                     |
| <b>1.3 System safety</b>                   |                                                                                                                         |
|                                            | <i>SEAMLES - Systems Engineering approaches for managing the life cycle of I&amp;C systems, VTT, Aalto</i>              |
|                                            | <i>SINARP - The Safe Interaction of Nuclear with a Renewable Rich Power System, Aalto, VTT</i>                          |

# SG2 – Reactor Safety and Fuel

| SG2                                         |                                                                                            |
|---------------------------------------------|--------------------------------------------------------------------------------------------|
| 2.1 Thermal hydraulics and severe accidents |                                                                                            |
|                                             | <i>ALISA - Analytical and experimental investigation of severe accident phenomena, VTT</i> |
|                                             | <i>CeReSa - CFD for Reactor Safety, VTT</i>                                                |
|                                             | <i>C-FLOW - Critical Flow Separate-Effect-Test Facility &amp; Experiments, LUT</i>         |
|                                             | <i>ESPO - Analysis of Passive Safety Systems' Operations and Modelling, VTT</i>            |
|                                             | <i>GRAF - Gravity driven flow experiments, LUT</i>                                         |
|                                             | <i>THEME - Computational Modeling of Thermal-Hydraulic Phenomena, VTT</i>                  |
| 2.2 Fuel and reactor physics                |                                                                                            |
|                                             | <i>DECAPOD - Deterministic safety analyses with Kraken, VTT</i>                            |
|                                             | <i>MATFINE - Methods for current and accident tolerant fuels modelling, VTT</i>            |
|                                             | <i>NOTCO- Neutronics for fuel outside the reactor core, VTT</i>                            |

# SG3 – Nuclear Waste Management

| SG3                                                                  |                                                                                                                                       |
|----------------------------------------------------------------------|---------------------------------------------------------------------------------------------------------------------------------------|
| 3.1 Fuel and Engineered Barrier System                               |                                                                                                                                       |
|                                                                      | <i>ABCRad - Alternative Buffer/Backfill Characterisation + Radionuclide Interactions, HU</i>                                          |
|                                                                      | <i>DEHYDSU - Defects, hydrogen and susceptibility of Cu-OFPP to stress corrosion cracking in sulphide containing environment, VTT</i> |
|                                                                      | <i>MOCRYCO - Model based on crystal plasticity for copper, VTT</i>                                                                    |
|                                                                      | <i>SAGE - Sensitivity analysis guided disposal barrier experiments, VTT, JyU, GTK</i>                                                 |
| 3.2 Low and Intermediate Level Waste & Waste management technologies |                                                                                                                                       |
|                                                                      | <i>GasOff - Termination phase of the LLW Gas Generation Experiment, Safram Oy, VTT</i>                                                |
|                                                                      | <i>MICWEST - Influence of environment and microbes on corrosion behaviour of welded steels in the LILW repositories, VTT</i>          |
|                                                                      | <i>POLYDEC - POLYelectrolyte gels for DEContamination, HU</i>                                                                         |
| 3.3 Rock, Site and Biosphere                                         |                                                                                                                                       |
|                                                                      | <i>ECOLAB - Laboratory-based studies for radioecological modelling of 14C, HU, FMI, UI, UEF, EnviroCase</i>                           |
|                                                                      | <i>FLOP - Flow pathways within faults and associated fracture systems in crystalline bedrock, UTU, GTK, JyU, Åbo Academi</i>          |
|                                                                      | <i>MIRKA - Scale-effect in fractured rock mass, Aalto</i>                                                                             |
|                                                                      | <i>SMRSiMa - SMR Siting and Waste Management, VTT, GTK, LUT</i>                                                                       |
|                                                                      | <i>DODGE - Dark oxygen in the deep geobiosphere of the geological repository, HU</i>                                                  |
| 3.4 Concrete                                                         |                                                                                                                                       |
|                                                                      | <i>FN-CAMP - Finnish Nuclear Concrete Ageing Management Project, VTT</i>                                                              |
|                                                                      | <i>PERCO2 - Long-term Performance Modelling of Concrete in Final Repositories of LILW Nuclear Waste, Aalto</i>                        |
|                                                                      | <i>RACEMAT - Radionuclide transport in cementitious materials, HU, GTK</i>                                                            |



# SG4 – Mechanical and Structural Safety of NPP’s

| SG4                                  |                                                                                                            |
|--------------------------------------|------------------------------------------------------------------------------------------------------------|
| 4.1 - Welds, fatigue and inspection  |                                                                                                            |
|                                      | <i>AI4NDE - Advanced and Intelligent Nondestructive Evaluation, VTT, Aalto</i>                             |
|                                      | <i>LOAD - Long-term Operation on Aging and environmental Degradation of nuclear reactor materials, VTT</i> |
|                                      | <i>TOFFEE - Total fatigue life in plant environment, VTT, Aalto</i>                                        |
| 4.2 - Materials and material testing |                                                                                                            |
|                                      | <i>AMANE - Additively Manufactured Materials in Nuclear Environments, VTT</i>                              |
|                                      | <i>BRIGHT - Barsebäck RPV investigation through thickness, VTT</i>                                         |
|                                      | <i>CHAOS - Characterization of NPP structural integrity, VTT</i>                                           |
|                                      | <i>MINERVA - Mitigation of corrosion and novel water chemistries in light water reactors, VTT</i>          |
|                                      | <i>PRANCS - Practical solutions for sealant performance issues in nuclear power plants, VTT</i>            |

# SG5 – Doctoral Education Network

| SG5 - DENSE |                                                                                                                          |
|-------------|--------------------------------------------------------------------------------------------------------------------------|
|             | <i>DENSECO - DENSE coordination project, Aalto, LUT, HU</i>                                                              |
|             | <i>REST - The reduction of large source term during severe nuclear accidents, UEF</i>                                    |
|             | <i>SurePhD - Increasing surety in the performance of present and future VLLW disposal - HU</i>                           |
|             | <i>MOXSEAL - Metal Oxides for Group Separation of Actinides and Lantanides, HU</i>                                       |
|             | <i>NCGDENSE- The measuring, modelling and development of non-condensable gas models for nuclear safety research, LUT</i> |

# SG6 - Infrastructure

| SG6                  |                                                                                                   |
|----------------------|---------------------------------------------------------------------------------------------------|
| 6.1 - Infrastructure |                                                                                                   |
|                      | <i>DEMAIN - Development and maintenance of LUT thermal hydraulic infrastructure, LUT</i>          |
|                      | <i>JHR2028 - Participation in the Jules Horowitz Reactor project, VTT</i>                         |
|                      | <i>RADCNS - Radiological laboratory facility costs of the Centre for Nuclear Safety 2023, VTT</i> |

# SAFER2028 Project abstracts

## 2024

- SG1 Overall Safety and Society
- SG2 Reactor Safety and Fuel
- SG3 Nuclear Waste Management
- SG4 Mechanical and Structural Stability
- SG5 Doctoral Education Network
- SG6 Infrastructure

# FASAANI (Fire behaviour and safety of nuclear infrastructure), VTT, Aalto

The FASAANI (Fire Behavior and Safety of Nuclear Infrastructure) project aims to provide new knowledge and validated simulation tools for assessing fire development and compartmentation layers in a nuclear power plant. The project has three different work packages. The first work package covers the complex interaction of fires with the ventilation system, which can lead to the breaching of the compartmentation layer. As there are no standardized ways or experimental possibilities to test system-level smoke compartmentation and its interaction with a fire, engineering analyses will be done based on numerical simulations. The second work package focuses on predicting the fire development of aged polymeric materials (e.g., cables) through pyrolysis modelling. Understanding and quantifying polymer ageing on the material flammability will be the main area of research here. Finally, the third work package will cover the fire barrier system (FBS), a critical compartmentation layer component to ensure fire resistance. The expert assessment –based approvals of FBS increase the uncertainty associated with the structure’s fire resistance and reduce the compartmentation reliability. Such concerns, along with the ageing effects on fire stops, will be addressed by laboratory – scale experiments and validation of modelling tools.

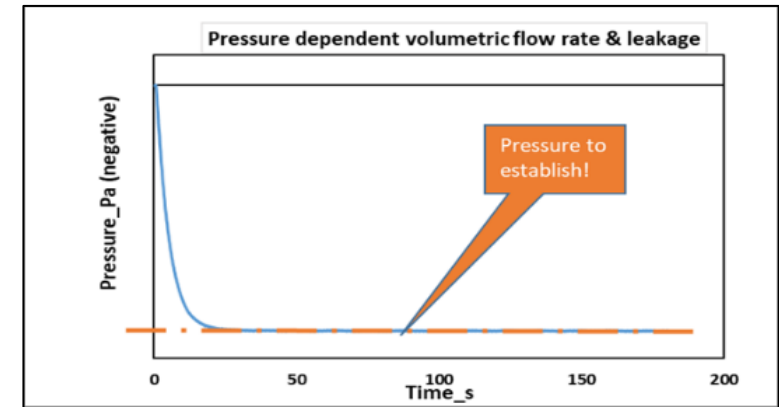
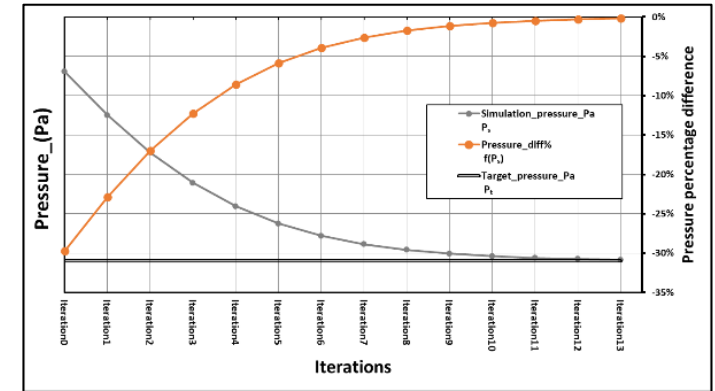

Top: Simulation pressure reaching the target pressure level with respect to time; Bottom: Pressure convergence and minimization of  $f(P_s)$  with various iterations

Image: FASAANI project

## **MAWECLI - Marine and Weather Events in the Changing Climate as Potential External Hazards to Nuclear Safety, FMI**

MAWECLI (MARine and WEather events in the changing CLimate as potential external hazards to nuclear safety) aims to increase preparedness towards single and compound marine and atmospheric extreme events that may pose external hazards at plant level in the changing climate. The project strives for enhancing methods on physical and statistical modelling, extreme value analysis and uncertainty quantification by joining expertise of scientists from various disciplines.

The results include estimates of the frequency and magnitude of high wind gusts, future sea-effect snowfall, and joint effect of intense snowfall and high wind speeds. We also make multi hazard assessment for convective storms, meteotsunamis and lightning, and produce improved estimates on coastal flooding risks, extreme air temperature, and worst-case flooding events caused by cyclones.

## **SERIOUS - Sensitivity and risk informed seismic hazard updates, VTT, RMCF, AFRY, HU**

The project targets a best-practice update to the seismic hazard models in use in Finland. It develops methods and refines understanding for keeping seismic hazard analysis of nuclear sites in Finland in line with the recent, major developments of the discipline. Seismic hazard is the key input for probabilistic risk analysis of nuclear installations, both for power plant and repository sites. Considering the future deployment of small modular reactors (SMRs), an understanding of the territorial distribution of the hazard, beyond the existing nuclear sites, is also targeted.

The focus is on quantification of the uncertainty of the inputs to the analyses, which improves the reliability of the hazard results. The goal is pursued along three main avenues: by exploring seismicity, ground motion, and utilization of rock mechanics. Decisions about seismic hazard levels in Finland are made on the basis of the observed low-magnitude seismic events. Seismicity features are therefore analyzed using simulations for the purpose of modeling risk-relevant scenarios. Ground-motion attenuation is investigated using the site-specific component of the kappa parameter. For future validation of dynamic simulations for both surface and subsurface ground motions, models of fault rupturing are investigated and benchmarking exercises conducted.

## **PRALINE - Probabilistic Risk Assessment Labour, Improvements and Extensions, VTT**

PRALINE carries out research in two selected subfields of probabilistic risk assessment (PRA): seismic human reliability analysis (SHRA) and the reliability of systems containing digitalized subsystems. SHRA concerns itself primarily with actions of control room operators after a seismic event has occurred, but it may concern also other personnel such as field operators. A state-of-the-art literature survey will be conducted, and issues related to SHRA will be clarified. Study on digital systems reliability consists of two research lines. The first consists of participation in DIGMORE, an international OECD NEA WGRISK benchmark study on a digital reactor protection system. The idea is to extend a previous benchmark study on the matter, DIGMAP project, to cover new modelling aspects on priority logics, backup systems, spurious actuations and others. The other research line concerns the assessing the impact of the complete set of instrumentation and control (I&C) systems on PRA. The focus is on the I&C architecture level. The goal is to get a better understanding on how, and on what level, architecture level interactions between I&C systems at different defense-in-depth levels should be accounted for in PRA.



## SCALA - Safety Culture and Leadership in Sociotechnical Changes and Transitions, VTT, Liliko

Wide-ranging sociotechnical changes impact the ways in which nuclear organizations organize and lead their operations, and what organizational approaches are effective for each context from nuclear safety perspective, and what are the roles and tasks of leaders and safety culture experts. SAFER2028 SCALA studies safety culture and leadership during sociotechnical changes and transitions. We examine the sociotechnical characteristics of major changes and identify ways of managing them. The main methods used in the project are case studies in Finnish NPPs, international data collection, participative development, comparative analysis, and modelling. In addition to case-specific results, the project develops a continuous improvement framework for resilient sociotechnical change for the Finnish nuclear industry. The framework contributes to leading, overseeing, and assessing nuclear safety aspects of sociotechnical changes and transitions.

## **TONUS - Towards Nuclear Human Systems Integration, VTT, FIOH**

The aim of the TONUS project is to promote the integration of human, technical and organizational factors in order to increase the stakeholders' (i.e., nuclear power plants, regulators and support organizations) resources for action in case of severe accidents and other fault situations. Our multidisciplinary research group will introduce a nuclear Human Systems Integration program providing a comprehensive, holistic framework for addressing human, technical and organizational factors at the plant level. Furthermore, we will develop methods and tools for further development of Human Factors Engineering activities, cognitive readiness skills training and assessment, transfer of virtual reality-based training and participatory design, visual inspection skills training and streamlining of field personnel's work practices through mobile technologies, which all will promote resilience in management of severe accidents and challenging incident situations. The results will contribute to nuclear safety at the national level by improving ability to respond, monitor and anticipate to both known and unknown threats.

# SEAMLES - Systems Engineering approaches for managing the life cycle of I&C systems, VTT, Aalto

SEAMLES develops deterministic safety assessment methods to use in the design and licensing of nuclear facility instrumentation and control (I&C) systems. The goal is to improve safety and operability by supporting re-engineering of I&C in upgrade and modernisation projects. The project focuses on (1) multidisciplinary analysis methods (e.g., Systems Theoretic Process Analysis (STPA) / Systems-Theoretic Accident Model (STAMP)) and (2) broadening the scope in which formal methods (e.g., model checking) can be applied. SEAMLES promotes Model-Based Systems Engineering (MBSE) practices to facilitate information exchange between engineering disciplines, ease the use of formal verification, and in general, improve precision in design.

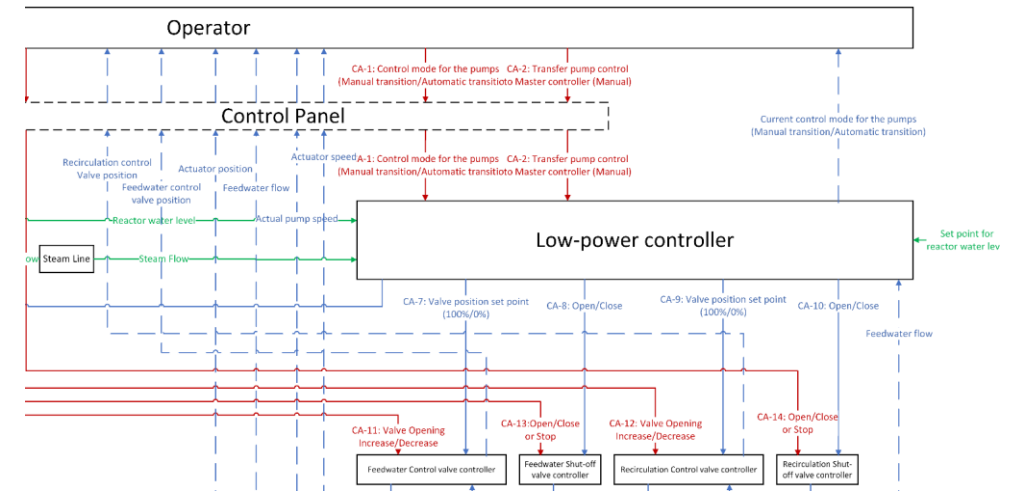

Extract of the hierarchical control structure for our OL 1&2 case study on STPA.

Image: SEAMLES project

# SINARP - The Safe Interaction of Nuclear with a Renewable Rich Power System, Aalto, VTT

Energy balance and stability are becoming of great concern in the grid. SINARP, (The **S**afe **I**nteraction of **N**uclear with a **R**enewable **R**ich **P**ower System) project will build on modelling done in the SAFIR/COSI project to investigate the impact of rapid swings in renewable generation and demand on the safe operation of nuclear power plants, and also investigate the role of nuclear in providing stability. The themes initiated in SAFIR will be continued, using the COSI co-simulation platform to investigate the impact on the NPP of faults in the power system during N-1 contingencies and low inertia (high wind) scenarios. Power system oscillations between the grid and the NPP will also be investigated.



400 kV grid model as delivered at end of 2023, showing wind park models (yellow) that have been added and have replaced older cruder models, and some new blocks (e.g. HVDC connections)

# ALISA - Analytical and experimental investigation of severe accident phenomena, VTT

The ALISA project combines the experimental and analytical research on severe accident phenomena by utilizing separate effect experimental facilities, and MELCOR and ASTEC severe accident analysis codes. The use of the facilities combined with the codes will produce new information on the safety significance of severe accident phenomena. The areas of interest include the analysis of relevant volatile organic compounds released from painted surfaces and the consequent formation of volatile fission product species. In addition, the management of both gaseous and aerosol species by pool scrubbing is of interest and will be investigated experimentally. To combine experimental work and modelling, the pool scrubbing experiments will be modelled using MELCOR or ASTEC analysis codes. MELCOR modelling will also be utilized to estimate the accuracy of the steel oxidation model and, if needed, update the state-of-the-art on this topic. ALISA project is connected to several international severe accident-related projects which improves the knowledge transfer and collaboration in the severe accident community. Overall, the ALISA project aims to strengthen the direct comparison and validation between experiments and simulations/codes and identify and evaluate the related uncertainties. The results will enhance nuclear safety in Finland.

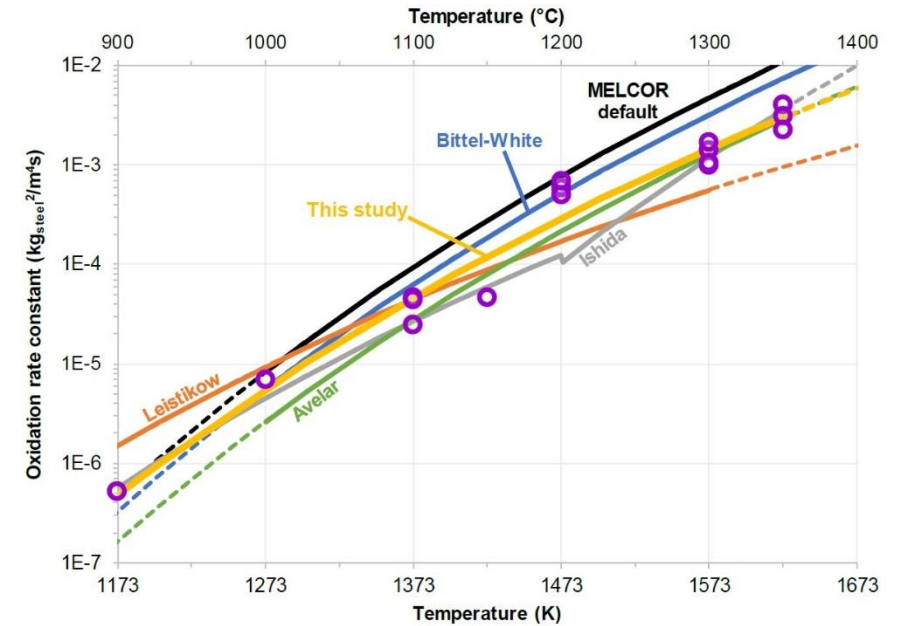

Oxidation rate constants derived from 16 experiments (purple circles), and six correlations.

Image: ALISA project

# GRAF - Gravity driven flow experiments, LUT

The modern nuclear power plant concepts contain systems relying on gravity driven natural circulation. The aim of the project is to improve understanding and modelling capabilities of phenomena related to gravity-driven flows in various nuclear power plant systems like the PWR primary circuit and passive safety systems. The scope of the project largely benefits the nuclear community in Finland and worldwide through studying various concepts and situations related to gravity-driven flows, not concentrating only on one specific situation or nuclear power plant type.

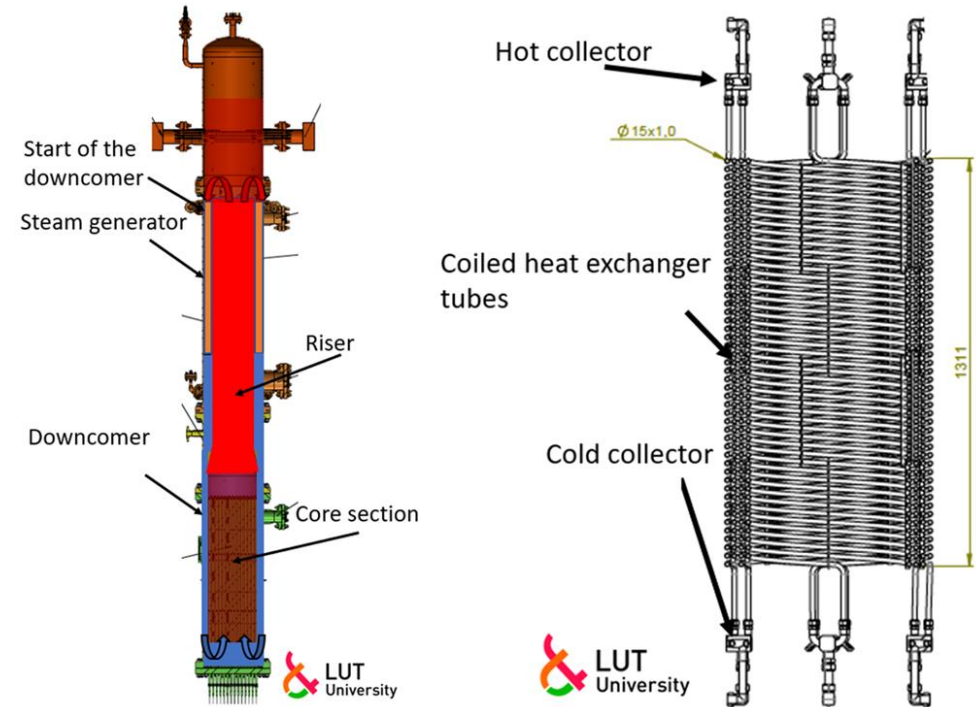

*Water flow paths in the primary side and steam generator tubes and collectors of the MOTEL facility.*

Image: GRAF project

## THEME - Computational Modeling of Thermal-Hydraulic Phenomena, VTT

The Computational Modeling of Thermal-Hydraulic Phenomena (THEME) project focuses on investigating various thermal-hydraulic phenomena through computational modeling. The project is tightly linked with separate SAFER2028 projects (GRAF and C-FLOW) in which thermal-hydraulic experiments are carried out at the LUT University, to establish a true cooperation effort that benefits both participating organizations and the SAFER2028 community in general. While the associated projects focus on actual conduction of thermal-hydraulic experiments, the THEME project provides support for them in designing the experiments for maximal value from the modeling point of view, helps analysing and understanding the experimentally-observed phenomena, and finally aims to develop new computational models to accurately describe the phenomena in a form that can be included in computational tools used for actual safety assessment of nuclear power plants.



## **ESPO - Analysis of Passive Safety Systems' Operations and Modelling, VTT**

The Analysis of Passive Safety Systems' Operations and Modelling Project (ESPO), seeks to use data from experimental facilities to investigate the dynamics of different passive safety systems and develop computational analysis methods for them. By doing so, the project hopes to expand our understanding of passive safety systems and identify any limitations in current analysis methods. The project is linked to two international projects (OECD/NEA ETHARINUS and OECD/NEA PANDA). In addition, the ESPO project has established joint research cooperation tasks with the French IRSN under the umbrella of ESPO (VTT) and PASTIS (IRSN) projects. ESPO also aims to increase and maintain national participation in the WGAMA Working Group and U.S. NRC CAMP Program.



## CeReSa - CFD for Reactor Safety, VTT

The overall objective of project CeReSa is to improve the usability and reliability of Computational Fluid Dynamics (CFD) calculations in Nuclear Reactor Safety (NRS) assessment. Open-source CFD methods will be developed and validated for the analysis of hydrogen transport in NPP containment. The methods will be compared with the models implemented in the commercial ANSYS Fluent code in a joint effort between VTT and Fortum. In addition, suitable international CFD benchmarks will be participated in. In 2023, post-benchmark analysis of the boiling models of OpenFOAM and other CFD codes will be analysed and improved.

# C-FLOW - Critical Flow Separate-Effect-Test Facility & Experiments, LUT

C-FLOW is a project where LUT will design, build, and commission a separate-effect-test (SET) facility capable of achieving critical flow conditions. In addition, in 2023 there will be proof-of-concept test(s) conducted. The modelling scenario is a steam generator tube guillotine break, in other words primary-to-secondary (PRISE) leak scenario. The SET will consist of upstream pressure vessel, a larger diameter measurement pipe and different length-to-diameter (L/D) discharge tubes in representative SG tube sizes of Finnish PWRs which are interchangeable. The maximum operating pressure for the upstream vessel is 10 MPa and temperature 270 °C. The SET will be thoroughly instrumented. On the one hand, the idea is to provide accurate data to SYS-TH code modelers and instrumentation will be planned in part taken these demands into account. On the other hand, the SET will act as a test bench for applying advanced measurement methods on critical flow studies within DEMAIN project. C-FLOW is co-operating with VTT's THEME project in order to share more knowledge between experimentalists and modelers. International co-operation will be made within FONESYS network through meetings and reflections of two-phase critical flow model development. In addition, Master's Theses within LUT will be conducted that are related to C-FLOW SET and two-phase critical flow in order to develop skills of new young experts joining nuclear field in Finland."

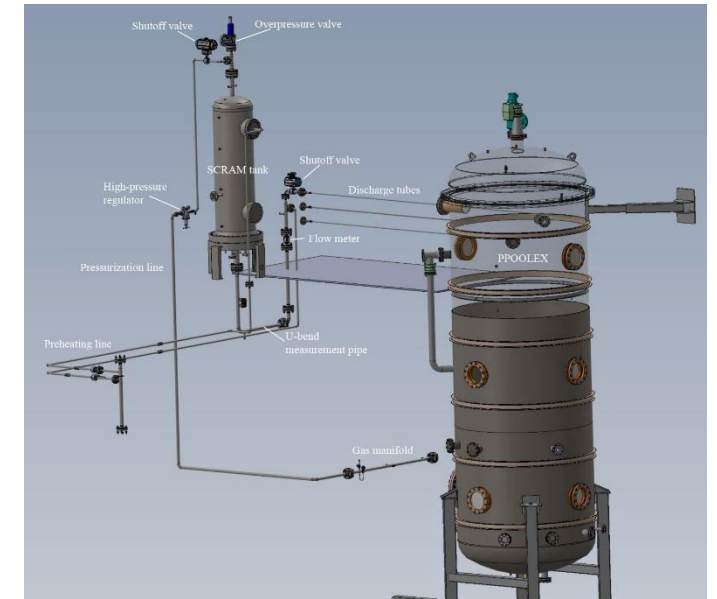

*CRAFTY (CRITICAL Flow Test facility) with its main components.*

*Image: C-FLOW project.*

## NOTCO- Neutronics for fuel outside the reactor core, VTT

The project aims at developing tools and expertise in computational spent nuclear fuel (SNF) characterization including the uncertainty quantification of SNF nuclide inventories. For propagating the nuclear data uncertainties, codes developed externally will be used. Previously, a computing platform has been established to utilize the Total Monte Carlo method with the T6 package (developed by PSI) and Serpent. Alternative options will be studied in NOTCO.

As part of the Kraken development, capability for SNF characterization with 3D full-core calculation will be enabled, thus upgrading the traditionally used 2D assembly-level calculation capability. Practically, the required routines for automatic data transfer between the Monte Carlo code Serpent and nodal core neutronics solver Ants will be implemented to the KrakenTools Python package.

Additionally, validating the computing tools for criticality safety with burnup credit and decay heat evaluations is included in the project. The work is performed under the OECD/NEA Working Party on Nuclear Criticality Safety benchmark exercises and/or with the help of SFCOMPO database or other applicable sources.

# MATFINE - Methods for current and accident tolerant fuels modelling, VTT

The MATFINE project covers both steady-state and design basis accident conditions. Cladding is analyzed experimentally by performing mechanical thermal creep tests and high-temperature steam oxidation tests that are linked with the IAEA Coordinated Research Program (CRP) “Testing and Simulation for Advanced Technology and Accident Tolerant Fuels” (ATF TS). A roadmap of installing the Crebello biaxial creep testing device into hot cell will be done in MATFINE to proceed with testing of irradiated cladding materials. For fuel behaviour in district heating SMRs, the effects of unconventional operating conditions, i.e., low temperature and low coolant pressure, will be analysed.

Continued development and validation of VTT’s in-house FINIX fuel behaviour module developed for coupled calculations is foreseen. New material correlations received from the IAEA CRP ATF TS will be implemented into FINIX. Improvement, verification and validation of a newly implemented cladding ballooning model for loss-of-coolant accidents (LOCA) in FINIX is done. VTT’s statistical script will be used for model parameter optimization in fuel performance codes. Fission gas release (FGR) from chromium additive ATF pellet is foreseen to be studied computationally. Further enhancement of the newly developed validation tool VAST is expected. As for the fuel behaviour in reactivity-initiated accident (RIA) conditions, the goal is to develop and maintain the knowledge on phenomena and modelling, especially with increasing burnup and new fuel types. Participation to international forums such as OECD/NEA Working Group on Fuel Safety (WGFS), FRAPCON/FRAPTRAN/FAST Users’ Group, CABRI International Project and Halden Reactor Project will be covered in MATFINE.



*Post-test photos and optical micrograph of a cross-section cut from the middle part of the TiAl coated sample exposed for 5 minutes. This sample had no filling powder.*

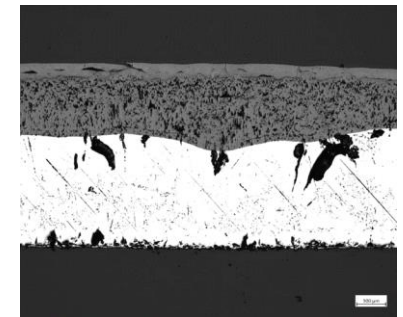

*Image: MATFINE project*

# DECAPOD: Deterministic safety analyses with Kraken, VTT

DECAPOD develops and validates the Kraken computational reactor analysis framework for the safety analyses of Finnish nuclear reactors. Specific targets for development and validation are the VVER-440 reactors of Loviisa and the boiling water reactors (BWRs) of Olkiluoto. The effort of the project is divided between developing some missing VVER-440 and BWR specific capabilities in the Kraken framework and the validation of Kraken for fuel cycle and transient analyses of these reactors.

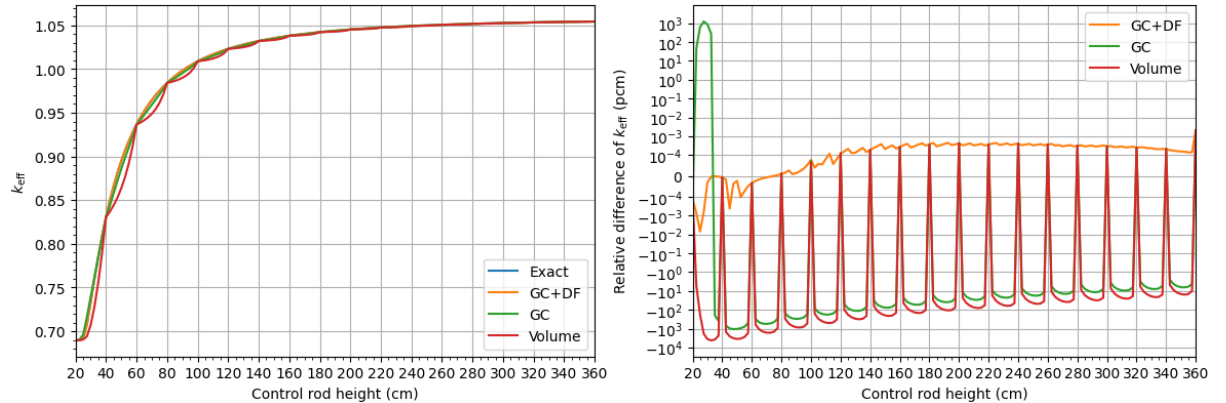

Effective multiplication factor (left) evaluated by Ants and the error in the evaluation (right) in a static control rod insertion calculation using old volume weighting (Volume) and axial homogenization (GC / GC + DF) approaches.

Image: DECAPOD project.



# DEHYDSU - Defects, hydrogen and susceptibility of Cu-OFP to stress corrosion cracking in sulphide containing environment, VTT

The authorities in both Finland and Sweden have raised concerns about the possibility of sulphide-induced stress corrosion cracking of the canister material, Cu-OFP, to be used as the main corrosion barrier in final disposal of spent nuclear fuel. This issue has been studied since 2008, focus revolving around the nature of micro-cracks (in the range of a few tens of micrometers) found by some on the surface of Cu-OFP after exposure to sulphide containing water, and the possible role of hydrogen in the mechanism.

In DEHYDSU-project, the research questions set are: 1) Does sulphide exposure induce surface defects (SCC micro-cracks) in Cu-OFP or are they formed due to pure mechanical loading only?, 2) Does hydrogen enter Cu-OFP to a sufficient degree during exposure to sulphide containing environment and induce SCC? and 3) Is the general corrosion rate of Cu-OFP in sulphide containing saline groundwater so high and the re-passivation rate so low that SCC becomes unlikely?

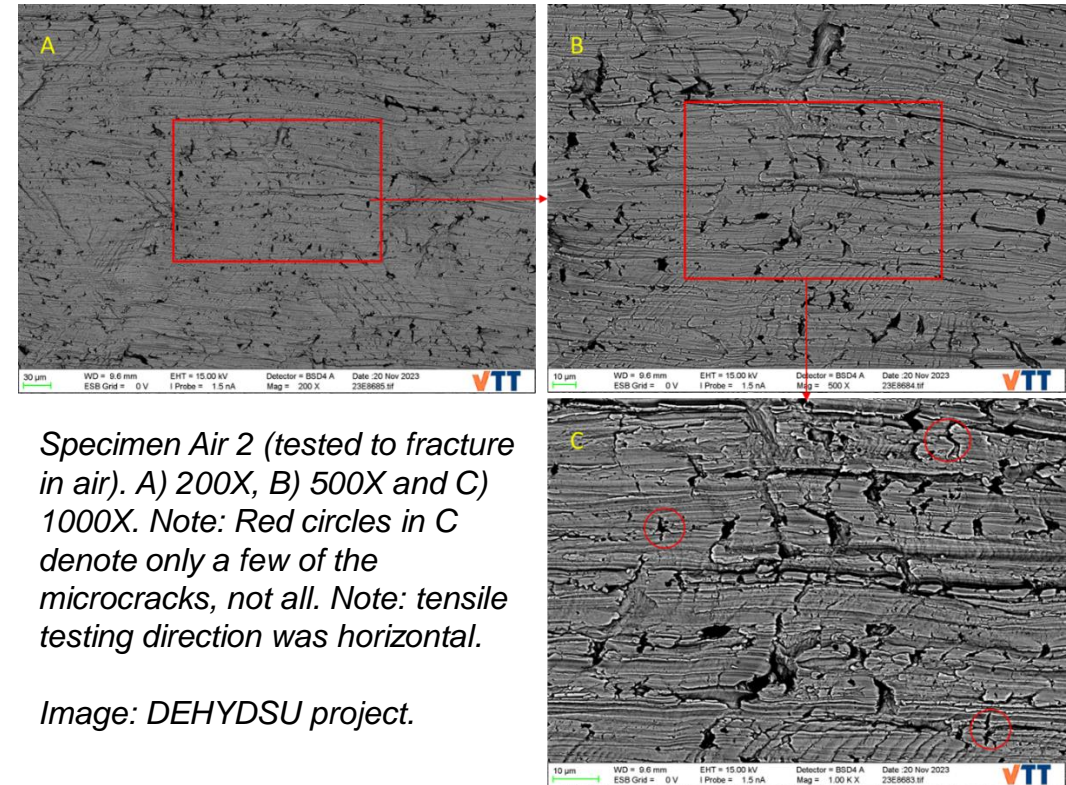

## **ABCRad - Alternative Buffer/Backfill Characterisation + Radionuclide Interactions, HU**

ABCRad aims to provide quantitative and mechanistic information for end-users on the properties of alternative bentonite materials, making them viable candidates as buffer / backfill material replacements for the current reference Wyoming-type bentonite. In ABCRad, we employ state-of-the-art analyses to study the physico-chemical structure of the materials, structural stability following heating, and interactions between the materials and radionuclides under conditions specific to ONKALO . Initially we will achieve this by determining  $K_d$  values and by studying the mechanisms governing solution-to-solid partitioning via Extended X-ray Absorption Fine Structure (EXAFS) spectroscopy and Time Resolved Laser Fluorescence Spectroscopy (TRLFS).

The results of the project will provide an enhanced understanding of material evolution and potential radionuclide interactions with the bentonites, directly informing the safety case for the storage of spent nuclear fuel.

## **SAGE - Sensitivity analysis guided disposal barrier experiments, VTT, JyU, GTK**

In this project, we tackle final disposal optimisation, feasibility as well as safety and performance assessment issues by a sensitivity analysis for the whole disposal system with the objective to reveal the material parameters that are the most important for safety and performance in the varied conditions. During the first project phase (the first half of the SAFER2028 programme), the scope of the analysis is limited to 1) hydro-chemo-mechanical continuum models and 2) saturating or saturated clay barriers in varying chemical and mechanical conditions set by the surrounding host rock. To reduce the number of needed experiments, the sensitivity analysis is utilised to guide the experimental work, where the main goal is a coherent set of measurements that gives values for the critical parameters. Instead of conventional measurement techniques, we apply state-of-the-art methods such as 4D (3 spatial dimensions + time) X-ray tomography, fast triaxial mechanical tests, chemical analysis techniques and calibrated electrical resistivity tomography that allow testing a large number of samples and conditions in multiple length scales from laboratory to entire disposal system scale. The main outcome of the project is 1) knowledge on the relative importance of the disposal components and their material properties for safety and performance, 2) means to optimize the barrier designs meaningfully, and 3) possibilities to evaluate safety even in cases where the barrier materials, configurations, and conditions change.



## **MOCRYCO - Model based on crystal plasticity for copper, VTT**

The project aims to gain more in-depth knowledge about the behaviour of oxygen-free phosphorus (OFP) copper and how the microstructure and segregation of chemical elements at grain boundaries affects it. The information is used to create a micromechanical model for relevant copper overpack material which accurately describes the material behaviour under mechanical stresses. Micromechanical model is used to formulate engineering model that can be used for component level analysis. Advanced characterisation methods are applied to study the chemical composition at grain boundaries and deformation microstructure of the material to gain more in-depth understanding on the deformation phenomena. The developed model will predict the evolution of the dislocation structure in relevant locations as well as the initiation and propagation of creep cavitation damage. As a result, it is aimed to introduce an original and expandable model that, based on the research done in the KYT2022 CRYCO and BECOLT projects, predicts the evolution of the dislocation microstructure in pertinent locations as well as the initiation and propagation of creep cavitation damage. The advanced and smart testing, characterization and modelling tools developed in the project are expected to find areas of exportation in several other applications, such as high temperature steel structures in energy and process industry, or future scenarios, such as new copper material grade beyond current OFP copper for final disposal canister.

## **MICWEST - Influence of environment and microbes on corrosion behaviour of welded steels in the LILW repositories, VTT**

The project aims to gain more in-depth knowledge about the behaviour of oxygen-free phosphorus (OFP) copper and how the microstructure and segregation of chemical elements at grain boundaries affects it. The information is used to create a micromechanical model for relevant copper overpack material which accurately describes the material behaviour under mechanical stresses. Micromechanical model is used to formulate engineering model that can be used for component level analysis. Advanced characterisation methods are applied to study the chemical composition at grain boundaries and deformation microstructure of the material to gain more in-depth understanding on the deformation phenomena. The developed model will predict the evolution of the dislocation structure in relevant locations as well as the initiation and propagation of creep cavitation damage. As a result, it is aimed to introduce an original and expandable model that, based on the research done in the KYT2022 CRYCO and BECOLT projects, predicts the evolution of the dislocation microstructure in pertinent locations as well as the initiation and propagation of creep cavitation damage. The advanced and smart testing, characterization and modelling tools developed in the project are expected to find areas of exportation in several other applications, such as high temperature steel structures in energy and process industry, or future scenarios, such as new copper material grade beyond current OFP copper for final disposal canister.

## **POLYDEC - POLYelectrolyte gels for DEContamination, HU**

Certain polyelectrolyte gels uptake radionuclides quite efficiently and they can be used for absorbing radionuclides from aqueous waste, water, steel, concrete, soil, etc. In this project, reaction conditions will be optimised to increase absorption capacity and hydrophilicity of the gel. This optimised gel can be used as a starting point for preparing a larger scale decontamination gel, which is hydrophilic or water soluble, entering pores of the contaminated concrete with easy peelability after drying. These properties can therefore decrease the volume of LILW produced in nuclear decommissioning and NPP operations. Polyelectrolyte gels can provide a safer and less contaminating decontamination method, compared to most of physical and many of chemical decontamination methods.

## GasOff - Termination phase of the LLW Gas Generation Experiment, Safram Oy, VTT

The focus of the GasOff project is in the microbially and corrosion induced gas generation from low-level operational waste in post-closure repository conditions. In addition, due to the setup of the large-scale gas generation experiment (GGE) the experiment will also offer unique samples for studying the corrosion of carbon steel and the degradation of concrete. Both the microbiological and chemical behaviour of the system offers unique results.

So far all the liquid and solid samples have been taken through the sampling pipelines. The dismantling of the GGE system will allow essentially extended sampling from the experiment tank, steel drums, waste bags, and the concrete box. The GGE was launched in the year 1997 and will be terminated in this project.



*Opening of the waste bags.*

*Image: GasOff project.*

# SMRSiMa - SMR Siting and Waste Management, VTT, GTK, LUT

SMRSiMa is a continuation project of a KYT2022 project. This project aims to build up on the knowledge obtained for SMR waste management in the SMRSiMa 2022 and SMRWaMa 2021 projects. Four research work packages are included with an additional work package for project management. The project is conducted together with GTK, LUT, and JYU with VTT being the coordinator.

For WP1 on SMR Spent Fuel Characteristics the aim is to perform full-core neutronics calculations with Serpent – Ants computing sequence for SMR cores. Properties relevant for final disposal, e.g., post-irradiation reactivity and decay heat, are calculated and compared to current spent fuel from large NPPs. In addition, amount of spent fuel generated in a SMR plant in comparison to NPPs remains as important research topic. WP2 focuses on centralised waste management strategy and adaptation of current disposal methods considering input from WP1 and SMRs designs relevant for Finland. As part of the waste management, issues such as offsite- and interim storage of spent nuclear fuel and extended fuel storage are assessed. Furthermore, work on mapping issues with the regulatory framework is conducted. WP3 continues work with siting of a SMR plant, centralised SNF repository and alternative disposal methods from geological perspective. WP4 on social engagement is related to plant and repository siting for SMRs. For example, Helsinki metropolitan area residents' opinions on alternative SNF waste management strategies will be assessed.

## **DODGE - Dark oxygen in the deep geobiosphere of the geological repository, HU**

This project investigates the presence and origins of free oxygen in continental deep groundwater environments. The study reconsiders assumptions about the anoxicity of deep geological repository environment by employing a multidisciplinary approach to evaluate the availability and effects of dark oxygen and hydrogen (microbial and radiolytic) as electron donors and acceptors for microbial processes in the deep subsurface. The study involves analyzing isotopes and isotopologues of oxygen, hydrogen and redox sensitive nutrients in groundwater samples and evaluating microbial metabolic potential through metagenomic and metatranscriptomic analyses. Additionally, a laboratory experiment will be designed to test hypotheses about dark microbial oxygen production at in-situ pressure conditions. The project expects to find (facultatively) aerobic microorganisms and active aerobic microbial processes in anoxic deep groundwater driven by microbially released oxygen.

# FLOP - Flow pathways within faults and associated fracture systems in crystalline bedrock, UTU, GTK, JyU, Åbo Academi

FLOP addresses the fluid flow properties of the bedrock, which, together with the seismic stability, is among the most important engineering-geological features of the bedrock in the Fennoscandian Shield area. Fluid flow within the bedrock is controlled by the networks of mechanical discontinuities, particularly faults and fault-related fractures, and these are the focus of this project. With respect to fluid flow, we will provide realistic models about the hydrogeological behaviour of geological structures. Here we place particular focus on testing the concept of channelized flow, using structurally controlled samples in micro-scale flow modelling experiments (micro-CT) and new DFN-tools. Outcomes of the present project will provide the industry and regulatory agencies updated knowledge and parameters for assessing the risks and creating solutions for the safe underground storage of nuclear waste which - key to achieving our global decarbonisation goals while minimising environmental impacts.

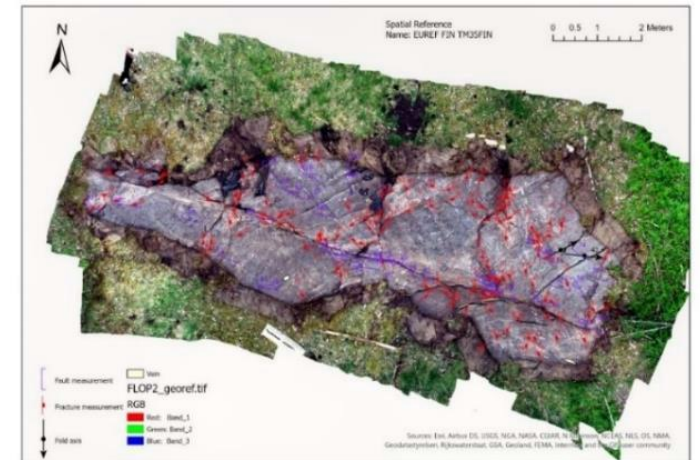

*Example of the documentation of bedrock sites.*

*Image: FLOP project.*



## MIRKA - Scale-effect in fractured rock mass, Aalto

The MIRKA research project studies the influence of scale on the fractured bedrock in the Fennoscandian shield area. The project focuses on two important rock mechanical features: the shear strength of rock joints resisting seismic activity and the fluid flow properties of displaced joints. For repositories situated within crystalline rock, the mechanical behavior of the rock mass and the fluid flow characteristics are largely dominated by fractures and fracture networks. The safety of such repositories is assessed using numerical modeling, but there are problems in upscaling from laboratory test results to site scale values. MIRKA conducts large-scale experiments to study the scale-dependency of rock joint shear strength and fluid conductivity using non-destructive photogrammetric predictions. To validate the numerical fluid flow simulations, rock samples with a discrete fracture network are scanned, numerically modelled, and tested in the laboratory. The MIRKA scale-effect results can be used to validate the safety of spent nuclear repositories. The physical discrete fracture network case will be shared as open data to be used as a benchmark case when assessing the goodness of numerical modeling approaches by experts and regulatory authorities.



*Close-range photogrammetry using a rotating table and a light-tent. Green ceramic calibration pieces can be seen on top of the Kury gray granite sample pair.*

*Image: MIRKA project.*



# ECOLAB - Laboratory-based studies for radioecological modelling of <sup>14</sup>C, H<sup>3</sup>U, FMI, UI, UEF, EnviroCase

The main objective of this project is to produce quantitative data on uptake of <sup>14</sup>C from below-ground sources (soil or sediment) into aquatic and terrestrial food webs, as implications for possible release from geological disposal of radioactive wastes as well as discharges from nuclear power plants. Such coordinated datasets are not available in many species and their relevant food webs. Therefore, to fill knowledge gaps in current radioecological models on <sup>14</sup>C radiological assessment and radiation safety further research on this radionuclide is needed. Furthermore, species-specific data sets will develop existing models by comparison of quantitative measures vs. predicted data, derived from computational platforms.

To investigate the transfer of <sup>14</sup>C in non-human biota, a novel approach is employed based on the use of a naturally cutaway peatland. There is a large difference in the isotopic abundance of <sup>14</sup>C between the cutaway peatland and the atmosphere. Isotope mixing models are applied to track the proportion of carbon from below-ground sources (soil/sediment) in living organisms. To minimize the risks associated with use of <sup>14</sup>C, <sup>13</sup>C is also used as a proxy to study the uptake of <sup>14</sup>C in several species. To the best of our knowledge this is the first study that directly evaluates the uptake of <sup>14</sup>C in aquatic organisms and terrestrial food webs. The findings of this work will shed new light on transfer of <sup>14</sup>C in non-human biota and develop the relation between aquatic and terrestrial ecosystems as inter-related units for risk assessment of <sup>14</sup>C in the entire biosphere.



Emergent; *Lysimachia nummularia* and *Stachys palustris*

Submergent (*Littorella uniflora*)

Free floating (*Lemna minor* or common duckweed)

*Plant species used for microcosm experiment.*

*Image: ECOLAB project.*

# PERCO2 - Long-term Performance Modelling of Concrete in Final Repositories of LILW Nuclear Waste, Aalto

PERCO2 research project addresses the research needs that focus on deterioration mechanism of reinforced concrete in low- and intermediate-level radioactive waste (LILW) repositories. The service life required of reinforced concrete at the final disposal includes an operational phase of about 100 years and a post-closure phase, which produce at least a design service life of 500 years.

The research include: (i) long-term assessment of the durability of concrete specimens stored in an environment similar to that of Finnish LILW repositories (ii) investigation of the potential of ecologically compatible types of concrete in LILW repositories and (iii) prediction of service life of reinforced concrete by numerical simulations of concrete aging with thermodynamical models.

The research project increases the safety of nuclear facilities by improving the aging management of reinforced concrete and creating a basis for a performance-based design approach for LILW repositories. Generally, NPP utilities will benefit from increased reliable service life of their concrete infrastructure. The research project will also educate new experts of reinforced concrete for nuclear power industry in Finland.

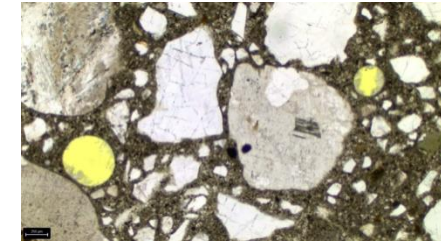
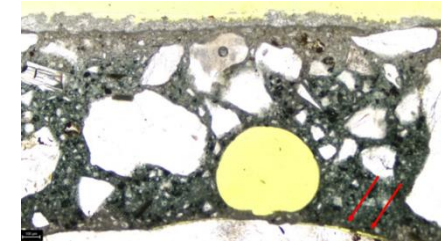
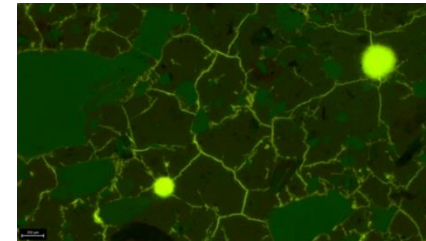

*Petrographic analysis of 25 years old concrete specimens. (a) example of very fine mesh micro-cracks (< 0.01mm), (b) the highlighted crack in concrete sample and (c) some secondary ettringite can be seen in the voids in this specimen.*

*Image: PERCO2 project.*

## RACEMAT - Radionuclide transport in cementitious materials, HU, GTK

This study investigates the radionuclides' transport in cementitious materials. Cementitious materials are commonly used to immobilise LILW waste and act as part of engineered barrier systems in Low- and Intermediate Level Waste (LILW) repositories. Highest uncertainties in the safety case of LILW are mostly related to behaviour of radionuclides with small or poorly known retention. Therefore, we aim to study the transport and retention properties of these safety case-important radionuclides.

Diffusion coefficients and distribution coefficients of HTO, C-14, Cl-36 and Ni-63 will be measured via through-diffusion experiments and autoradiography. We will also characterise the in situ concrete-based waste material in terms of 3D microstructure, distribution of activity and chemical speciation of radionuclides. This study will produce safety case-relevant information on the transport properties of LILW radionuclides in cementitious materials commonly encountered in LILW repositories. New experts on radioactive waste management are planned to be trained during the course of this study and the skills of senior experts are kept up to date.

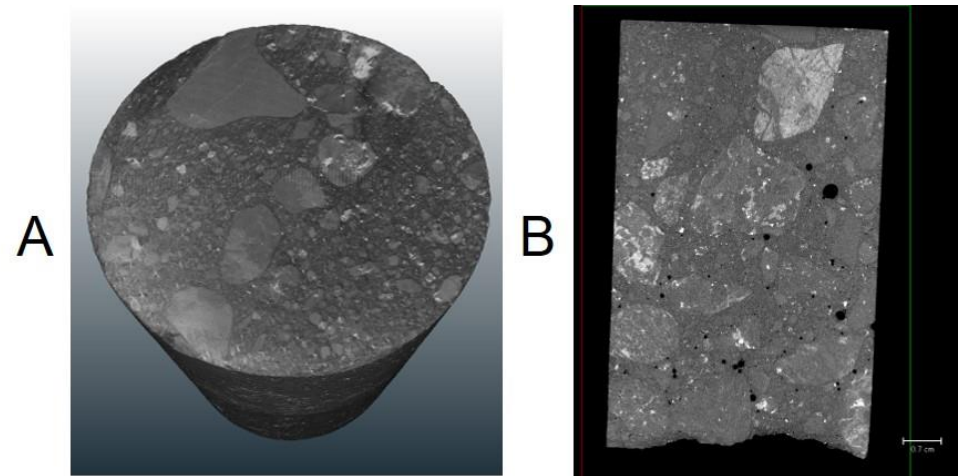

*Example of X-ray tomography analyses of repository basin concrete. A: Top-Down view; B: Side view.*

*Image: RACEMAT project.*

# FN-CAMP - Finnish Nuclear Concrete Ageing Management Project, VTT

FN-CAMP is a research project that focuses on supporting ageing related aspects for both Finnish NPP concrete infrastructure and Finnish radioactive waste repository concrete structures. The FN-CAMP project aims at having a significant impact on the safety of operational Gen II and Gen III NPPs and impact the long-term performance of concrete repository structures. FN-CAMP will improve the understanding of ageing/deterioration of concrete and will provide tools and guidance to the assessment of safety margins for structural performance. The outcomes from FN-CAMP will therefore support the ageing management of NPPs and concrete repository structures and help prepare NPPs for LTO. The selected ageing mechanisms studied in FN-CAMP correspond to research areas of recognized knowledge gaps of high importance to Finnish NPPs and RWSs. The concrete ageing mechanism addressed are alkali-silica reaction, aggressive aqueous attack, embedded liner corrosion and spent fuel pool liner corrosion, containment monitoring data analysis. The FN-CAMP project will have impact through:

- Identification of key relevant knowledge gaps for ageing processes of reinforced concrete SSCs in the frame-work of transition from ageing management (AM) to LTO of relevance for Finnish NPPs and RWSs.
- Development of an assessment tool for ASR expansion in concrete will contribute to predicting the behaviour of concrete under various exposure conditions (e.g., relative humidity, temperatures, and confining stresses), and thus improve our understanding of the mechanism of ASR expansion.
- Development of an assessment tool to predict the deterioration of concrete exposed to an aggressive aqueous environment will contribute to evaluating the deterioration degree of concrete and comparing the deterioration rate at given exposure durations.
- Increased understanding of the corrosion mechanism enables greater precision in term of location of corrosion locations, reducing the costs of inspections.
- Results will contribute to improved modelling capabilities which will enable better maintenance and ageing management practices of containment and pool liners.
- Increased understanding of the structural behaviour of the pre-stressed containment building during short-term events, such as pressure tests, and long-term behaviour, such as leak-tightness in aged concrete structures.
- Contribution to development of an overall strategy within the EU for the safe life long-term prediction of reinforced concrete SSC's for NPPs and RWSs.
- Dissemination of best practice guidelines for performance assessment related to key ageing and deterioration mechanism and lifetime management of reinforced concrete.
- Contribution to improvements in cost-effectiveness and safety of both existing and future NPPs and RWSs.



# TOFFEE - Total fatigue life in plant environment, VTT, Aalto

TOFFEE focuses on evaluation of the safe operation life of primary piping in plant environment. Environmental degradation, thermomechanical fatigue and subsequent cracking remains one of the ageing mechanisms that limit the lifetime of nuclear piping. The project provides experimentally verified means to determine the total safe lifetime of primary piping with respect to fatigue and crack growth in coolant water environment and subjected to relevant stressors. The considered ageing mechanisms are environmental fatigue for the crack incubation period and thermomechanical crack growth and stress corrosion cracking during the crack growth period. The experimental studies of the degradation mechanisms are complemented with analytical approaches needed to link the material behaviour measured in laboratory conditions to the true behaviour of the component in actual plant conditions.

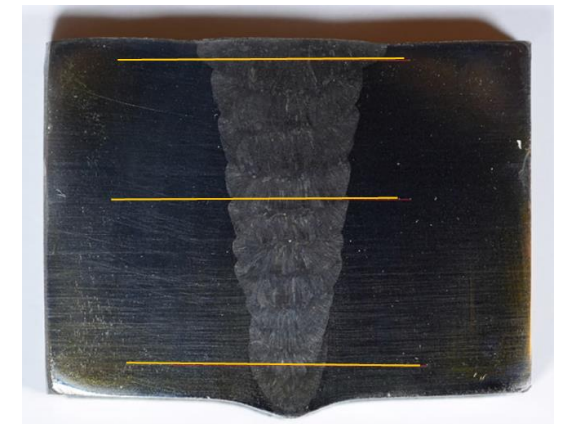
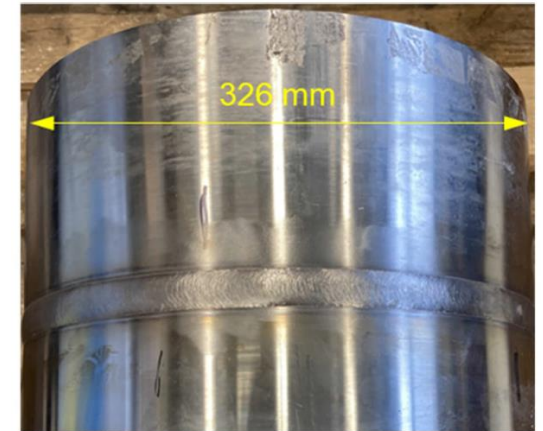

*Top: 316L pipe welded with NG-GTAW method. Bottom: Weld cross-section*

*Image: TOFFEE project.*

# LOAD - Long-term Operation on Aging and environmental Degradation of nuclear reactor materials, VTT

The project will address the key material topics relevant to reliable plant operation. The most important metallic structural material groups of NPPs are low-alloy reactor pressure vessel steel, austenitic stainless steels, nickel-base alloys and the dissimilar metal welds between them. EPRI degradation matrix workgroup has identified environmental effects on components, stress corrosion cracking (SCC) and thermal aging of these materials as key knowledge gap areas for long-term operation (LTO). The same degradation mechanisms are critically relevant for the Finnish NPP fleet. The overarching objective of LOAD project is to gain understanding on environmental degradation mechanisms in NPP component materials – including long term thermal embrittlement and environmental assisted cracking (EAC), etc.

The LOAD project aims to increase the knowledge on SCC of cold worked stainless steels and the potential influencing factors, fill the knowledge gap of thermal aging concerning 22k steel used in VVER design and improve the understanding of the role of thermal aging on hardness increase and EAC behavior of Alloy 690. Furthermore, the LOAD project will play a key role in the knowledge development on LTO and environmental degradation and knowledge transfer to the young scientists and engineers in the Finnish nuclear community. The LOAD project will strengthen also the international cooperation on LTO and EAC of nuclear reactor materials under the framework of the International Cooperative Group on Environmental Assisted Cracking (ICG-EAC) and act as the national information exchange platform for the ongoing EU-DELISA, EU-INCEFA-SCALE and NKS-FEMMA projects.

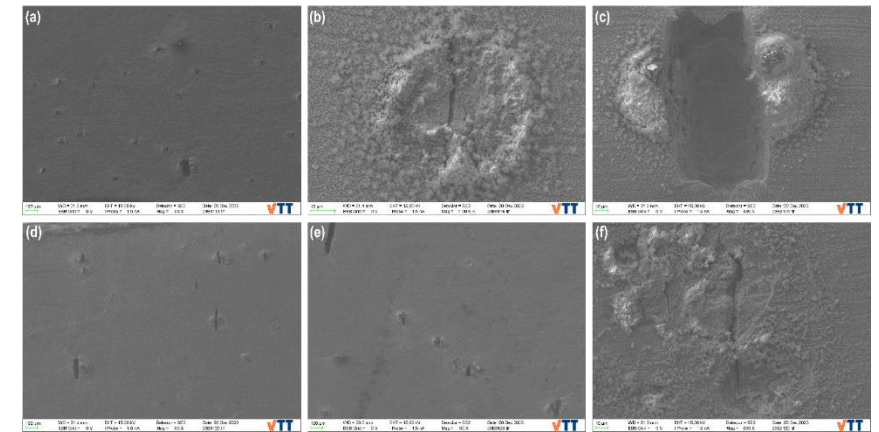

*SEM graphs of the 22K steel in (a-c) as-received condition and (d-f) 5 kh aged condition.*

*Image: project.*

# AI4NDE - Advanced and Intelligent Nondestructive Evaluation, VTT, Aalto

The Nondestructive Evaluation (NDE) methods have been proven inevitable in the safety diagnosis of Nuclear Power Plants (NPPs) from the construction phase to Plant Life Extension (PLE) strategies.

The previous SAFIR project on NDE showed the feasibility of Artificial Intelligence (AI) for nuclear inspections. The first generation of AI models for nuclear NDE is reaching the level of maturity needed for qualified use, and the first qualified inspections using AI are expected in the next few years. Continued work on the topic is important to ensure sufficient background research and education of new experts for the successful adoption of this breakthrough technology.

AI4NDE seeks to support the maturity of the NDE innovations introduced in the previous projects and provide significant improvements. While the current research has mainly focused on AI for flaw detection, this project moves to tackle the more complicated crack characterisation and sizing. The AI classification-style models used for crack detection will be replaced by segmentation models. In addition, successful sizing will require multi-model or ensemble architecture, where lower-level models extract regions of interest that are then further processed using higher-level models, and multiple parallel higher-level models are combined to exploit information from, e.g., multiple Ultrasonic Testing channels.

Furthermore, the project studies the reliability of flaw sizing in Ultrasonic Testing using probabilistic and/or AI approaches.

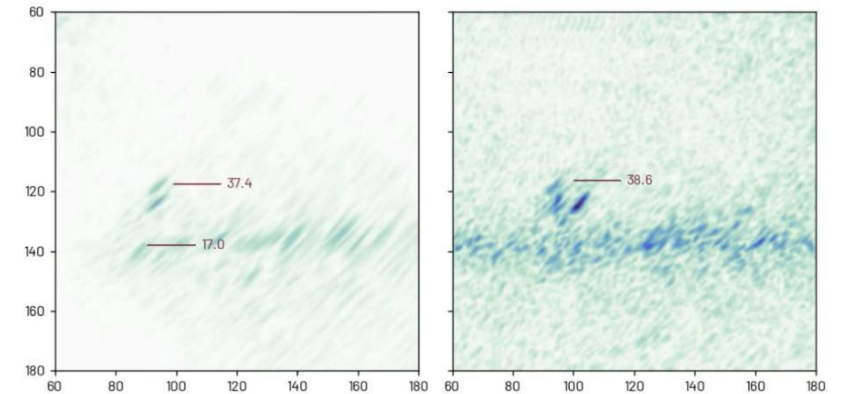

*Detection and sizing by the developed AI model.  
Left: SATFM image. Right: TFM image*

*Image: AI4NDE project.*

# BRIGHT - Barsebäck RPV investigation through thickness, VTT

Ensuring safe operation and the durability of the reactor pressure vessel (RPV) is one of the most important tasks for nuclear power plants. The condition of the RPV must be known to ensure for safe nuclear power production. Radiation-induced embrittlement especially in the core-region is the most pronounced ageing mechanism of the RPV. The embrittlement is monitored through a surveillance program and mechanical testing. Research material from a decommissioned Barsebäck RPV has been made available and the determination of the mechanical and microstructural properties has started. The real component material can be compared to the surveillance program opened with the BREDA project as well as to study the true embrittlement after operation.

The research plan consists of three work packages, 1) fracture mechanical testing, 2) microstructural characterisation, and 3) dissemination and SMILE participation. Fracture mechanical testing focuses on four thickness locations through RPV wall to investigate the variability in embrittlement. Low-alloy steel base material and weld metal are studied in thermally aged condition and in thermally aged and irradiated condition. Brittle fracture initiation sites are investigated for microstructural features and the initiation sites are further analyzed using advanced characterization methods, e.g., transmission electron microscopy (TEM). Publications and communication with the industry and partners is in core part of the project excellence. The results and outcomes of the investigations of the Barsebäck RPV material properties provide VTT an in-kind access to SMILE consortium.

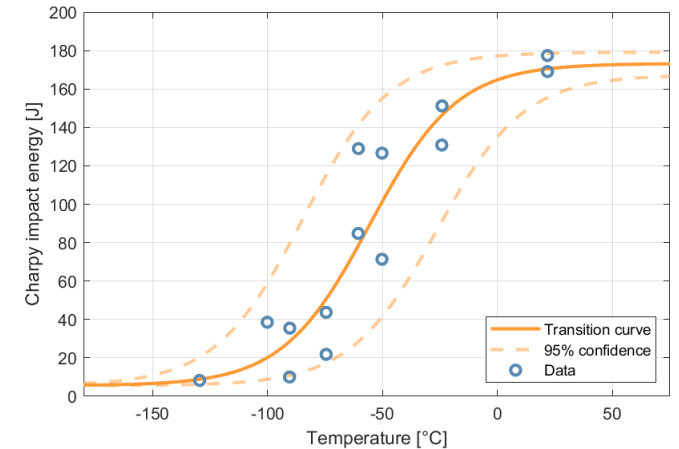

*The ductile to brittle transition curve of the impact toughness test results from the RPV head mase material.*

*Image: BRIGHT project.*



# CHAOS - Characterization of NPP structural integrity, VTT

In this project, the objective is to develop state-of-the-art fracture mechanical assessment methods for use in NPP applications, and improve safety by developing more accurate structural integrity assessment methods, to account for transferability of fracture toughness to real components (= the constraint-effect), and at the same time, offer a solution for diminishing volume of RPV surveillance material caused by extending lifetimes of NPPs. The latter goal is focused on optimizing the miniature C(T) specimen testing technique for surveillance programs and developing a miniaturization technique to assess crack arrest toughness. The CHAOS project focuses on method development of experimental fracture mechanical research, but also metallography and numerical methods are essential to reach the objectives of the project. Later the validated methods can be applied in surveillance programs, and they are universally applicable to diversity of materials. Development work will also support experimental research in the hot cell environment.

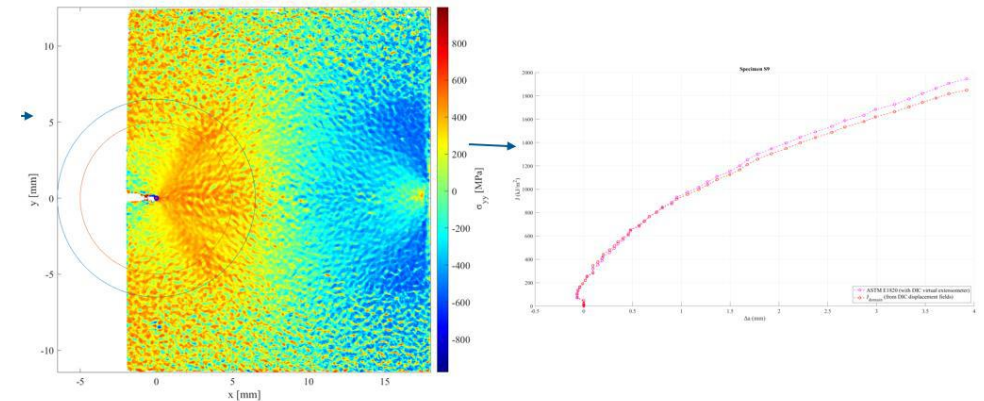

*Stress estimation from strains measured by DIC and consecutive full-field J-integral calculation.*

*Image: BRIGHT project.*

# AMANE - Additively Manufactured Materials in Nuclear Environments, VTT

As a digital, toolless technology, Additive Manufacturing (AM) could improve the availability of spare parts for old equipment and installations and support the safe long-term operation of nuclear power plants in Finland. Despite the increasing presence of additive manufacturing in industrial environments, also in nuclear, there is still a lack of standards and knowledge of material properties, structural integrity and inspectability of resulting components. In recent years, several standards have been released in connection with the aerospace industry. And even if there are ongoing activities working on this development, there is still missing a standard or guideline about the usage of AM manufactured components in the nuclear industry.

In AMANE, the objective is to go beyond the work being done in the standardization activities and further investigate some of these aspects not covered there, but which have been identified as important towards the safe use of AM components in NPPs. In particular:

- Obtain quantitative data on the stress corrosion cracking of typical materials used in nuclear environments (e.g., AISI 316L AM) under conditions relevant to BWR environment.
- Improve the testing methods and analysis of fatigue properties of materials considering the peculiarities of the AM process (anisotropy, localized defects, surface quality ...).
- To increase the knowledge on material behaviour of Ni alloys specifically suited of nuclear applications but not generally used in other industrial fields.
- The additional knowledge gained by these activities is essential in ensuring the safe operation of AM components and can support all Finnish stakeholders in the qualification process of these components in nuclear power plants.

# MINERVA - Mitigation of corrosion and novel water chemistries in light water reactors, VTT

The MINERVA project aims to provide solutions for chemistry and corrosion related issues that the currently operating plants in Finland have, as well as the potential SMR designs in future will face. Both primary and secondary side chemistries are studied in MINERVA. The current challenges in primary water chemistries are currently related in the Western type of PWRs to pH adjustment chemical and radiation build up due to corrosion products. Currently LiOH is applied in Western designed PWRs as a pH adjustment chemical. However, due to the availability issues of Li-6 there is a demand for alternative pH adjustment chemical, namely KOH, which is already applied in VVER plants. In MINERVA the status of LiOH-KOH transition studies is summarized, and future research needs estimated. The second primary side topic studied in MINERVA is the evaluation of Co source term. In MINERVA the source term of Co is evaluated, i.e. how much Co is dissolved from Co containing alloys and other materials that have Co as an impurity alloyed within them.

The secondary circuit topics studied in MINERVA include hydrazine replacement chemicals, deposition of corrosion products and impurities in steam generators and on-line monitoring of corrosion products from process water. Hydrazine is applied in secondary circuits as an oxygen scavenging chemical and although it possesses good scavenging properties, its use might be restricted in future due its carcinogenicity. Alternative scavenger chemicals are studied based on their scavenging efficiency, decomposition products and effects to corrosion of structural materials. Steam generator corrosion issues are studied by investigating the deposition of impurities (e.g. Cl and SO4) to boiling surfaces.

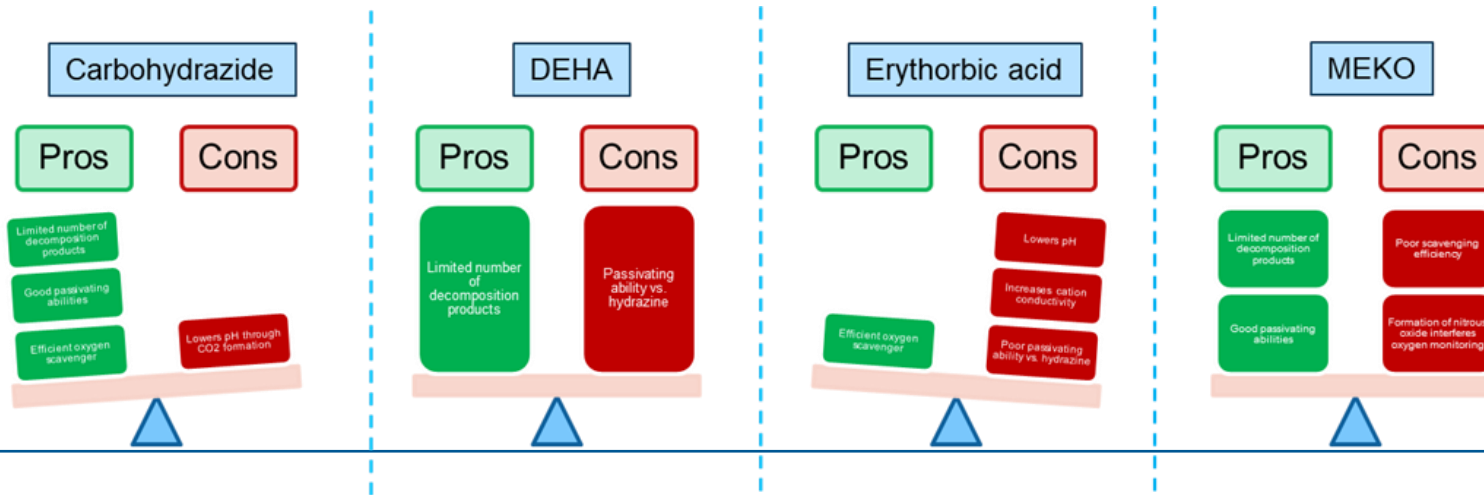

Summary of the hydrazine studies.

Image: MINERVA project.

## **PRANCS - Practical solutions for sealant performance issues in nuclear power plants, VTT**

The objective of the project is to ensure the safe and long-term operation of sealant components in various nuclear power plant applications. The project bases on the SAFER2028 small project SINAPP, where sealant related issues were reviewed. As a result of this study a SAFER project is proposed where the identified issues are studied in more detail to produce practical solutions. The work is conducted in three work packages (WPs). The first WP focuses on developing hardness measurement to be used as a condition monitoring method for joint sealants used in reactor buildings. The second WP focuses on different ageing phenomena on sealants: ageing under compression, ageing in nitrogen atmosphere and chemical stability of sealants. The third WP studies the performance of graphite sealants in high temperature water and under dynamic loading.

## **SurePhD - Increasing surety in the performance of present and future VLLW disposal - HU**

SURE-PhD supports efforts towards safe surface level disposal of VLLW in Finland. We will (1) document 14C behaviour in the current Finnish VLLW disposal concept; (2) assess if contaminated materials sourced from future Finnish NPP decommissioning could be safely disposed in current existing Finnish VLLW surface disposal concept, and therein understand the evolving chemistry of the disposal system; and (3) investigate whether other waste packaging materials (namely low pH cement and novel geopolymers) could improve the overall safety of future VLLW surface disposal by lessening radionuclide release from the wastes (e.g., for VLLW management from Olkiluoto 3, future Finnish NPPs, SMRs etc.).

## **DENSECO - DENSE coordination project, Aalto, LUT, HU**

DENSECO-project covers the coordination activities and networking operations of the Doctoral Education Network DENSE. Our objective is to support networking of doctoral students implementing their DENSE projects, both within DENSE network, domestically, and internationally. Additionally, all other doctoral students working in SAFER2028 projects will be invited to DENSE network activities. We expect to establish an annual seminar for doctoral students in the DENSE network. We also expect to financially support doctoral students in participation fees of conferences, workshops, and summer schools, as well as their national and international mobility and costs related with publications, equipment, and materials.

## **REST - The reduction of large source term during severe nuclear accidents, UEF**

The overall objective of the doctoral project titled “The reduction of large source term during severe nuclear accidents” is to improve the safety of the existing and future nuclear power plants by developing technologies to prevent the large-scale particle emissions during the hypothetical severe nuclear accidents and educating new experts in the field. The expected results of the project will improve understanding and generate new knowledge that will be in the development of new filtration technologies for aerosols, especially cesium and iodine species, by applying high efficiency electrostatic precipitators. In addition, the applicability of the electrostatic precipitators for controlled hydrogen mitigation will be investigated. The project will be carried out in collaboration with the international and national network providing an excellent framework for the studies. The project will also closely interact and share knowledge with national and international stakeholders through various communication channels.

## **MOXSEAL - Metal Oxides for Group Separation of Actinides and Lantanides, HU**

The project aims to investigate group separation materials for actinides and lanthanides from porous metal oxides. The porosity will create an ion sieve effect and together variation on pore diameter selectivity toward Ac – Ln will be adjusted.



## **NCGDENSE- The measuring, modelling and development of non-condensable gas models for nuclear safety research, LUT**

Comprehending the dynamics and potential effects of non-condensable gases (NCGs) on the reactor coolant system is crucial. NCGs in the reactor coolant system can have various adverse effects and lead to accidents and transients. Thus, studying NCG release and dissolution is vital. The NCGDENSE project aims to investigate the release and dissolution of NCGs through analytical, experimental, and numerical means. Theoretical modelling of NCG dissolution and release phenomena will be performed. A SET facility will be constructed to perform NCG release and dissolve tests using novel instrumentation and measurement techniques and the test section will be upgraded to optically transparent ones. Pattern recognition algorithms will be developed and implemented to extract fundamental details of NCG experiments. This algorithm will generate data for model validations. The NCGDENSE project aims to improve the modelling of NCG release and dissolution of SYS-TH codes. The release and dissolution models for NCG will be implemented in the SYS-TH codes. The results of this project will be published in high-level journals and conferences.

## **RADCNS - Radiological laboratory facility costs of the Centre for Nuclear Safety 2023, VTT**

The VTT Centre for Nuclear Safety is a national infrastructure hosted by VTT. It has an important role in enabling independent capabilities for safe, domestic nuclear power production and responsible waste management. VTT's Centre for Nuclear Safety provides a variety of facilities and equipments for us in testing and analyzing radioactive materials. The RADCNS project is specifically targeted for support in the second part of the call described in VN/21022/2022, and as described in the Nuclear Energy Act Amendment (676/2015), YEL § 53 a.

## **DEMAIN - Development and maintenance of LUT thermal hydraulic infrastructure, LUT**

The purpose of the DEMAIN project is to develop and maintain the experimental thermal hydraulic infrastructure at LUT University (LUT) nuclear safety research laboratory in Lappeenranta. The project includes maintenance of the thermal hydraulic test facilities and development and upgrade of the facilities, instrumentation and data acquisition and analysis capabilities. Knowledge management is also a part of the project, comprising the implementation of the new data storage systems of the laboratory. The project also includes significant international co-operation with other top-level universities and research institutes conducting experimental nuclear thermal hydraulic research worldwide in the frame of the SILENCE network.

# JHR2028 - Participation in the Jules Horowitz Reactor project, VTT

SAFER JHR2028 - Participation in the Jules Horowitz Reactor project contains participation to the research programmes of JHR consortium, using Finnish experimental and analytical infrastructure. Similarly to previous years, VTT's experts will participate in JHR Working Group meetings twice a year, to disseminate information regarding the status of JHR construction and to present the status of Finnish in-kind contributions to the project. Furthermore, additional international collaborative activities are included in the project, such as the continued participation to Halden reactor project legacy database development, and OECD NEA FIDES meetings and activities. In continuation to the previous SAFIR JHR projects, VTT's bi-axial creep test device MeLoDIE II will be manufactured for the conditions of the in-core of the LWR-15 test reactor in the Czech Republic, for investigating the behavior of fuel cladding under controlled bi-axial loading. Preliminary testing of the device will be performed in Finland, after which the equipment as a whole will be transferred to LWR-15. MeLoDIE II is a necessary development for the JHR Project, since MeLoDIE III device will be adapted and designed as an in-kind contribution to JHR in the future.

A new focus point for JHR2028 will be the initial characterization of the JHR Archive Materials (JAM), which is a collaborative project between JHR Materials Working Group members. JAM project aims to define future material irradiations in the JHR MTR based on known and anticipated needs regarding both actual nuclear fleet life extension and future nuclear technologies.

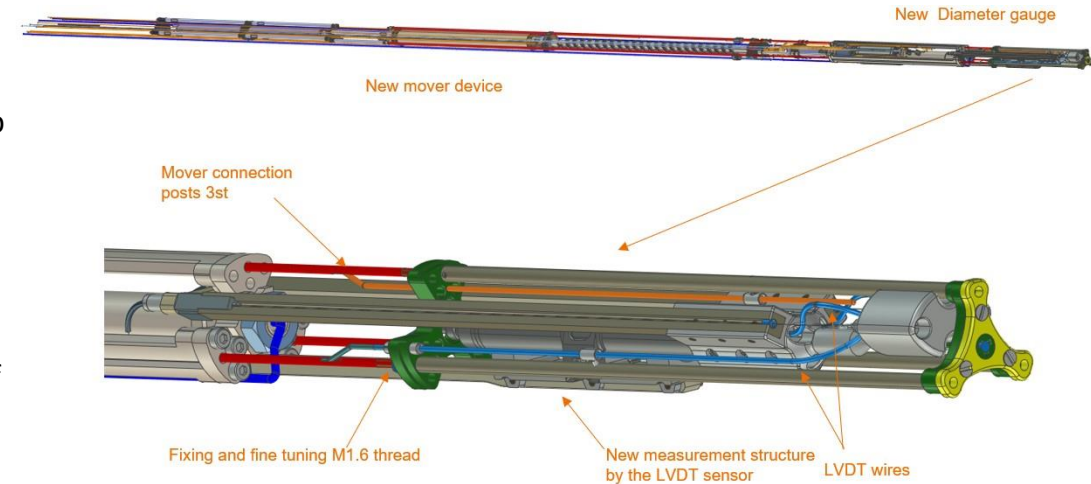

*Recent updates to the Melodie design.*

*Image: JHR2028 project.*

# SAFER2028 Administration Contact Information

Twitter: @SAFER2028



Website: <https://safer2028.fi/>



Email: [safer2028@vtt.fi](mailto:safer2028@vtt.fi)



Programme director  
Suvi Karvonen

[suvi.karvonen@vtt.fi](mailto:suvi.karvonen@vtt.fi)  
040 356 2536



Project experts Anna  
Korpinen & Aku Itälä

[anna.korpinen@vtt.fi](mailto:anna.korpinen@vtt.fi)  
040 159 1156  
[aku.itala@vtt.fi](mailto:aku.itala@vtt.fi)  
040 833 6473